

SlimStile S

SlimStile S

Tripod turnstile for Internal or External Installation

Technical Specification

Drive: Hand operated

Orientation: Pass Left or Pass Right

Materials:

Casework:	304 Grade grained Stainless Steel (EN 10088-2 Grade 1G/2G)
Casework Lid:	304 Grade grained Stainless Steel (EN 10088-2 Grade 1G/2G)
Tripod Hub:	Cast aluminum with painted grey finish
Tripod Arms:	38m dia. 480mm 316 Grade Satin Polished Stainless Steel (EN 10088-2 Grade 1K/2K) with welded end caps

Function: Passage in both directions, electronically controllable

Mechanism: Control of the Tripod operation is achieved by an electro-mechanical head mechanism located within the top section of the turnstile casework. It is silent in rotation and comprises the following standard features: -

- A positive lock action that prevents two passages at one time
- A self centering mechanism to ensure complete rotation of the mechanism to the home position
- A hydraulic damper to ensure smooth operation
- Anti backup device to prevent reverse rotation once the mechanism has moved 60° from home

Operating Modes: The mechanism can be configured to operate in two standard modes.

- Normally Closed – The mechanism is locked until a valid authorisation signal is received.
- Normally Open – The mechanism is permanently unlocked and will only lock if passage is attempted without a valid authorised signal. In this mode the MTBF are significantly increased from 1.5 to 2.5 million cycles, it reduces power consumption and increases passage throughput speeds.

Power Failure: In the event of an emergency or isolation of the power supply, the tripod can be configured to fail-safe, i.e. rotates freely, or fail-lock, i.e. locks in the home position. Either option is available in both or one direction. As standard tripods are configured bi-directional fail-safe unless specifically requested otherwise.

Fire Alarm – Input facility available for 0V contact supplied by others to effect the fail state.

Interface: Note - Mechanism fail state will be the same as power failure choice
The mechanism is controlled via the LL2001 Lite microprocessor control logic with the following standard features: -

- One input for opening/locking the mechanism in each direction
- Two protected outputs for control of the opening/locking solenoids
- Four protected outputs for piloting way mode indicators
- Two protected outputs for counting passage in ether directions
- Two 0V output relays indicating availability of use in either direction or for counting passage in ether direction.
- Two open collector NPN outputs to count passage or to indicate availability of use in either direction or activate the optional drop arm feature.
- One serial port –RS485.



Product Description

The SlimStile S provides a basic but effective, economical tripod for either internal or external installations, with smooth, virtual silent operation.

Users include

- Government
- Retail
- Finance
- Telecommunications
- Information Technology
- Banking
- Publishing
- Leisure
- Petrochemical
- Education

Regulate

Unit has an adjustable time out facility if required i.e. Go signal will be cancelled if passage through turnstile is not completed within pre-set time. The standard default is 8 seconds adjustable via parameter change.

The logic is protected against short circuits, overloads, and polarity inversion. Additional detailed information is available upon request

Power Supply: 115/230V AC 50/60Hz

Power Rating: N/C - stand by or passage use 50VA, alarm condition 50VA
(Per Walkway) N/O - stand by or passage use 5VA, alarm condition 50VA

Logic Voltage: 24V DC

Delivery Details: The SlimStile S range is delivered fully assembled and may require lifting gear for off loading.

Models Available

SlimStile Electrical Tripod Turnstile

- Model SE Single Walkway – electrically controlled in one or both directions
- Model SDE Double Walkway – each side electrically controlled in one or both directions.
- Model SDUM Dummy casework to house card reader or create walkway

Standard Accessories and Optional Extras

Alternative Materials, Finishes and Custom Design (Please contact Gunnebo Entrance Control Ltd for suitability and costs)

- Casework available in other materials

Cardreader Mounting (Please refer to Gunnebo Entrance Control Ltd for feasibility)

- Surface mounting only of customer supplied readers
- Cardreader Pedestals

Additional Interface

- Serial port RS485

Status Lights

- 50mm dia. LED display Status Lights flush mounted within the turnstile lid top face. The Green badge symbol is continuously illuminated indicating passage is available. Upon authorisation a Green arrow will illuminate in the direction of passage authorisation whilst in the opposite direction a Red cross symbol will illuminate to indicate the unit is not available for use or is all ready in use.

Push Button Control

- Simple remote Push Button Console
- Remote console to specific requirements
- Single pushbutton casework or lid mounted

Usage Counters

- Electro-mechanical, re-settable or non-re-settable counters inside tripod OR visible through cutout in casework

Drop Arm

- In the event of an emergency or isolation of the power supply the horizontal tripod arm will drop automatically to create a clear walkway for escape. Input facility is available for potential free contact supplied by others to effect the fail state. As standard the drop arm is supplied as a bi directional fail lock mechanism.

Mechanical Operation

- Non-electrical unit allowing free movement in one direction – reverse direction locked

External Installation Upgrade

- 316 Grade Stainless Steel
- Seal kit
- Heater kit for extreme conditions (Please contact Gunnebo Entrance Control Ltd for advise)

Installation Examples



SlimStile SE

SlimStile SDE

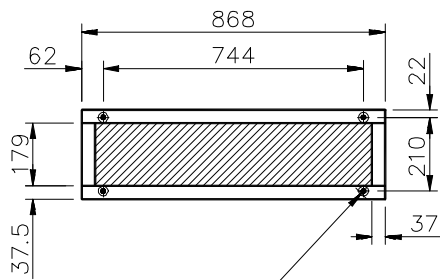
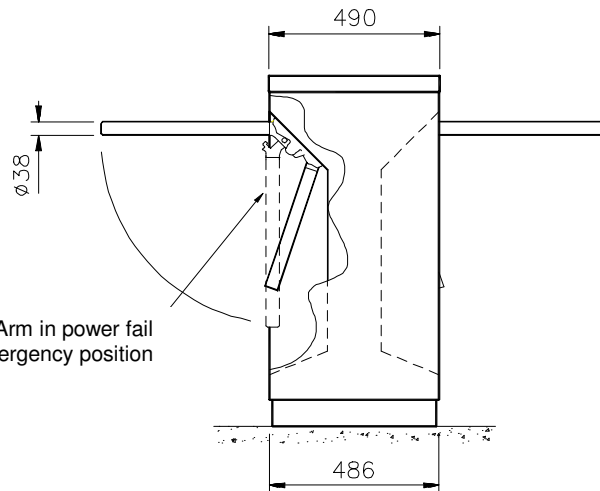
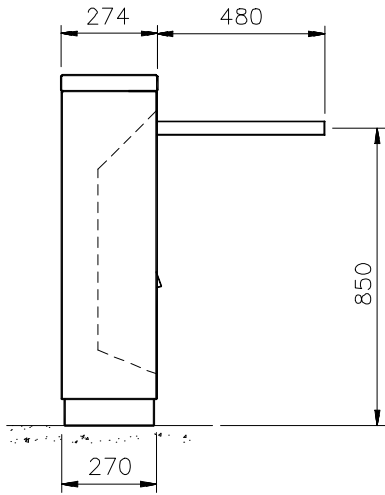
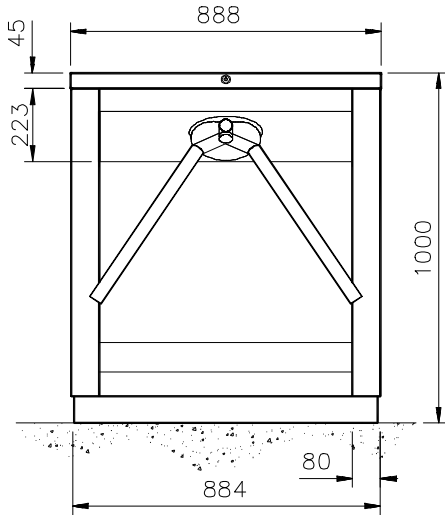

Floor anchor position, drill 12mm dia x 100 deep min. (drilled during installation)

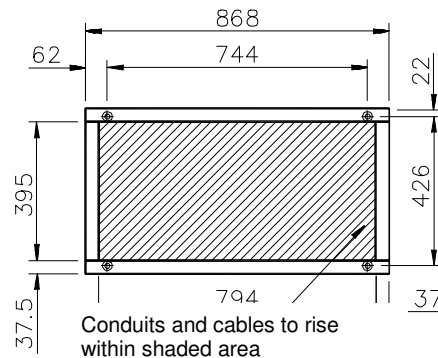

Conduits and cables to rise within shaded area

Concrete to BS 5328: 1997 specification, type ST5.
 Base to be flat and level to +/-5mm over footprint area.
 SE - 1200 x 500 x 150mm min
 SDE - 1200 x 600 x 150mm min

IMPORTANT

- Any horizontal pipe or conduit runs below the SlimStile must be at least 140mm below

Flow Rates

Reader Device	Number per minute
Insertion type	10
Swipe type	15
Proximity 'Hands Free'	20

- Please note the figures are approximate and must be confirmed with Gunnebo Entrance Control Ltd. Figures quoted are for one person per complete passage per walkway and per minute. It is assumed the access control authorisation response is instantaneous. Flow rates will increase with multiple passage use.

For sales enquiries please contact:



Competence Centre Entrance Control

Gunnebo Entrance Control Ltd. Bellbrook Business Park, Uckfield, East Sussex, TN22 1QQ, UK.
Tel +44 (0) 1825 761022 Fax +44 (0) 1825 763835
E-mail info@gunneboentrance.co.uk
Web www.gunneboentrance.com



A COMPANY WITHIN THE GUNNEBO

HEAD OFFICE SWEDEN
Gunnebo AB, Box 5181, SE-402 26 Goteborg, SWEDEN. Tel +46-31 83 68 00, Fax +46-31 83 68 10

www.gunnebo.com

Note: In pursuit of its policy of continuous refinement and improvement, Gunnebo Entrance Control Ltd reserves the right to modify design and details.